

IF IN DOUBT ASK
DO NOT SCALE

BOX VIEWED FROM REAR

A

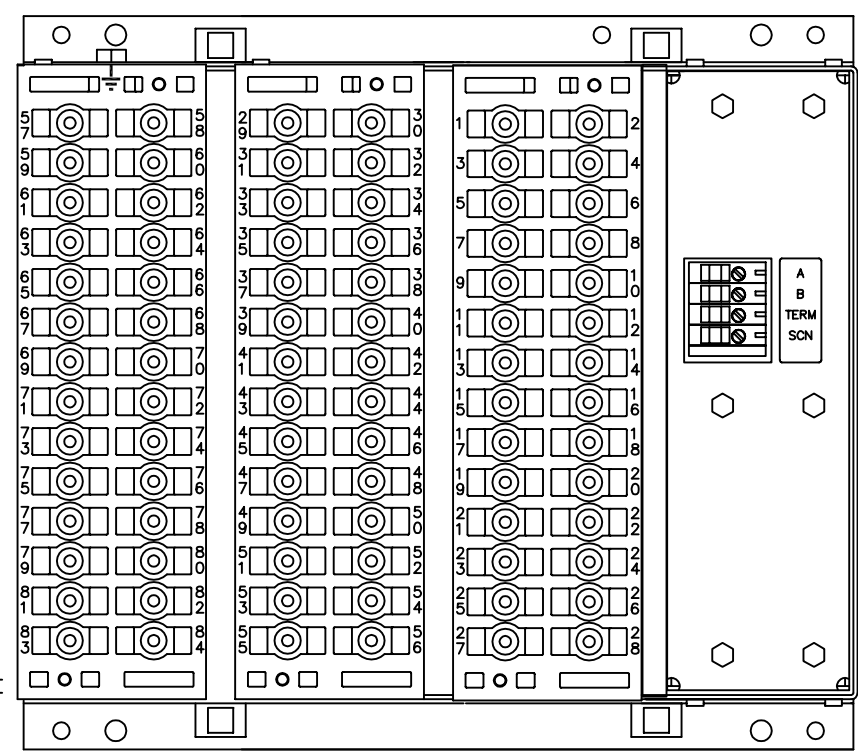
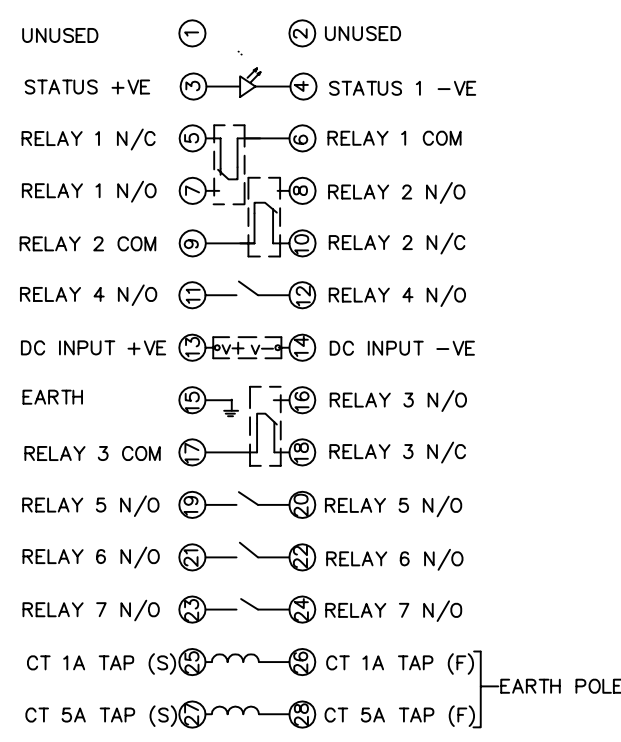
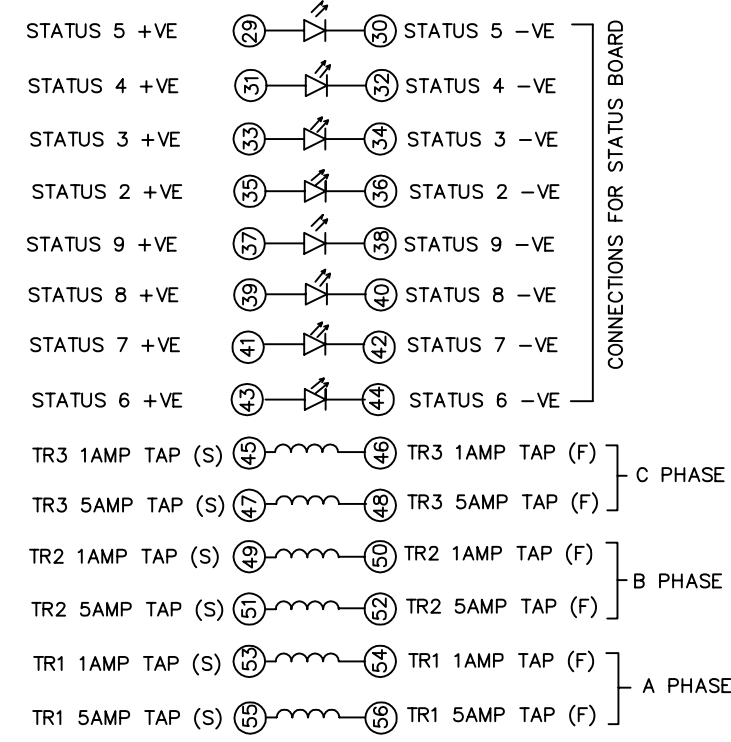
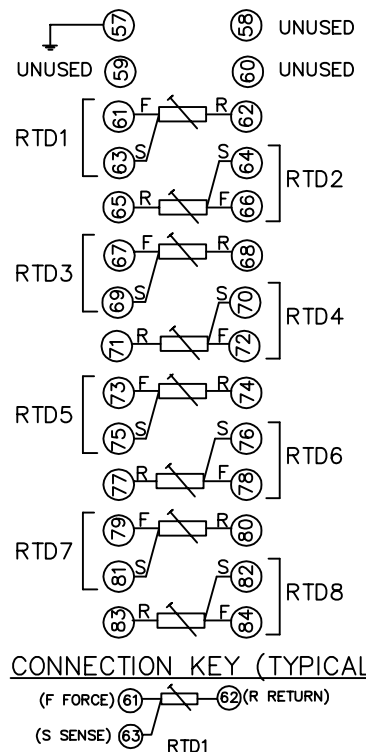

CONNECTION KEY (TYPICAL)

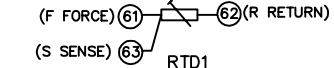

OUTER TERMINAL BLOCK ASSY:-
VIEW BLOCK FROM THE INSIDE FACE

58	S	S	57
60	S	S	59
62	S	S	61
64	S	S	63
66	S	S	65
68	S	S	67
70	S	S	69
72	S	S	71
74	S	S	73
76	S	S	75
78	S	S	77
80	S	S	79
82	S	S	81
84	S	S	83

ASSEMBLY INSTRUCTIONS:-
TYPICAL ASSEMBLY DRAWING 2995G10029
AT INDICATED POSITIONS FIT AS FOLLOWS,
S - FIT STANDARD CONTACT
2995B10051
HC - FIT 'HEAVY CURRENT' KIT
2995G10030
WHERE IS SHOWN FIT
CT SHORTING KIT 2995G10031
POSITIONS SHOWN BLANK ARE UNUSED
ALL POSITIONS FIT SCREW 2101F12506

OUTER TERMINAL BLOCK ASSY:-
VIEW BLOCK FROM THE INSIDE FACE

30	S	S	29
32	S	S	31
34	S	S	33
36	S	S	35
38	S	S	37
40	S	S	39
42	S	S	41
44	S	S	43
46			45
48			47
50			49
52			51
54			53
56			55

ASSEMBLY INSTRUCTIONS:-
TYPICAL ASSEMBLY DRAWING 2995G10029
AT INDICATED POSITIONS FIT AS FOLLOWS,
S - FIT STANDARD CONTACT
2995B10051
HC - FIT 'HEAVY CURRENT' KIT
2995G10030
WHERE IS SHOWN FIT
CT SHORTING KIT 2995G10031
POSITIONS SHOWN BLANK ARE UNUSED
ALL POSITIONS FIT SCREW 2101F12506

OUTER TERMINAL BLOCK ASSY:-
VIEW BLOCK FROM THE INSIDE FACE

2	S	S	1
4	S	S	3
6			5
8	S	S	7
10			9
12	S	S	11
14	S	S	13
16	S	S	15
18			17
20			19
22	S	S	21
24	S	S	23
26			25
28			27

ASSEMBLY INSTRUCTIONS:-
TYPICAL ASSEMBLY DRAWING 2995G10029
AT INDICATED POSITIONS FIT AS FOLLOWS,
S - FIT STANDARD CONTACT
2995B10051
HC - FIT 'HEAVY CURRENT' KIT
2995G10030
WHERE IS SHOWN FIT
CT SHORTING KIT 2995G10031
POSITIONS SHOWN BLANK ARE UNUSED
ALL POSITIONS FIT SCREW 2101F12506

CHASSIS TERMINAL BLOCK ASSY:-
VIEW FROM NUMBERED SIDE OF BLOCK

2	S	S	1
4	S	S	3
6	S	S	5
8	S	S	7
10	S	S	9
12	S	S	11
14	S	S	13
16	S	S	15
18	S	S	17
20	S	S	19
22	S	S	21
24	S	S	23
26	S	S	25
28	S	S	27

ASSEMBLY INSTRUCTIONS:-
TYPICAL ASSEMBLY DRAWING 2995G10032
AT INDICATED POSITIONS FIT AS FOLLOWS,
T - FIT TRIP ISOLATION CONTACT
2995B10053
S - FIT STANDARD CONTACT
2995B10054
POSITIONS SHOWN BLANK ARE UNUSED

CHASSIS TERMINAL BLOCK ASSY:-
VIEW FROM NUMBERED SIDE OF BLOCK

2	T	T	1
4	T	T	3
6	T	T	5
8	T	T	7
10	T	T	9
12	T	T	11
14	T	T	13
16	T	T	15
18	S	S	17
20	S	S	19
22	S	S	21
24	S	S	23
26	S	S	25
28	S	S	27

ASSEMBLY INSTRUCTIONS:-
TYPICAL ASSEMBLY DRAWING 2995G10032
AT INDICATED POSITIONS FIT AS FOLLOWS,
T - FIT TRIP ISOLATION CONTACT
2995B10053
S - FIT STANDARD CONTACT
2995B10054
POSITIONS SHOWN BLANK ARE UNUSED

CHASSIS TERMINAL BLOCK ASSY:-
VIEW FROM NUMBERED SIDE OF BLOCK

2	S	S	1
4	T	T	3
6	S	S	5
8	T	T	7
10	S	S	9
12	T	T	11
14	S	S	13
16	T	T	15
18	S	S	17
20	T	T	19
22	T	T	21
24	T	T	23
26	S	S	25
28	S	S	27

ASSEMBLY INSTRUCTIONS:-
TYPICAL ASSEMBLY DRAWING 2995G10032
AT INDICATED POSITIONS FIT AS FOLLOWS,
T - FIT TRIP ISOLATION CONTACT
2995B10053
S - FIT STANDARD CONTACT
2995B10054
POSITIONS SHOWN BLANK ARE UNUSED

NOTES

1 TERMINALS RECOMMENDED ARE PRE INSULATED & MUST BE CRIMPED USING APPROVED TOOLING.
AMP PIDG OR PLASTI GRIP FUNNEL ENTRY (RING TONGUE) FOR M4 FIXING STUD.

SUPPLIER	AMP	CABLE SIZE
AMP	342103	0.25-1.6 SQ MM
AMP	342143	1.0-2.6 SQ MM.

OR ANY OTHER MANUFACTURERS EQUIVALENT TERMINAL.

2 FOR OUTLINE & DRILLING DRG SEE 2995X10008 (A4).

PROTECTION TYPE	SCHEMATIC DIAGRAM
LINE CTs	2681W10010 (A3)
SEPERATE CORE BALANCE CTs	2681W10009 (A3)

**NOT SUBJECT TO UPDATE
ONCE COPIED / PRINTED
OR DOWNLOADED**

MATERIAL:

Dimensions in millimetres : Surface texture in micrometres. Machine where marked ✓ For explanation of dimensions, tolerances, notes etc. see B.S.308. Limit on untoleranced unmachined dimensions ± _____ Limits on untoleranced machined dimensions to B.S.4500; i.e. up to 6±0.1; over 30 to 120±0.3; over 315±0.8; over 6 to 30±0.2; over 120 to 315±0.5; General unmachined angular tolerance ± _____	Finish: _____ Treatment: _____	Title: TERMINAL IDENTIFICATION & RELAY WIRING DIAGRAM RHO 3 MOTOR PROTECTION WITH RTD & RS485 COMMS. E8 CASE	First used on: _____ Similar Articles: _____ Supersedes: _____
	SIEMENS PROTECTION DEVICES LTD.	Original Scale: NTS	Drg. No. 2681W50004
	DRAWN RDW CHECKED RDW APPROVED R.D.WATSON	DATE 30/01/07 IE OPS PCP Purch.Spec. TQ EAC	CE STD A3

Copyright © 2007 Siemens Protection Devices Ltd. Hebburn

1	30/01/07	CHANGE NOTED
ISSUE	DATE	NOTED